

User's Guide – NBC 2005, Structural Commentaries (Part 4 of Division B)

Errata

Issued by the Canadian Commission on Building and Fire Codes

The table that follows lists errata that apply to the User's Guide – NBC 2005, Structural Commentaries (Part 4 of Division B).

The errata are corrections that have been identified; they are provided to facilitate the use of the Structural Commentaries. Certain pages from the User's Guide have been updated for your convenience; they are provided following the table.

Contact your local authority having jurisdiction to find out if these errata apply in your province or territory.

Provision	Erratum	Date of Issue
Commentary G		
Figure G-8	The second Figure Note was corrected to read as follows: (2) If b is less than $3S_s/\gamma$, in m, then the effect of the obstruction on the snow loading can be ignored.	07-12-01
Commentary I		
Figures I-2, I-3 and I-4	The following text was added at the end of the Figure titles: (Reproduced with the permission of the National Capital Commission ©NCC/CCN)	07-12-01
Figure I-5	The following text was added at the end of the Figure title: (Reproduced with the permission of The Helicopter Company Inc., Toronto, Canada, 2003)	07-12-01
Paragraph 22	The equation in the second sentence of the example at the end of the paragraph was corrected to read: $\delta = 5 \times 10^{-5} \text{ m}^3/\text{N}$	07-12-01
Figure I-7	This Figure was replaced with the one on the following page:	07-12-01

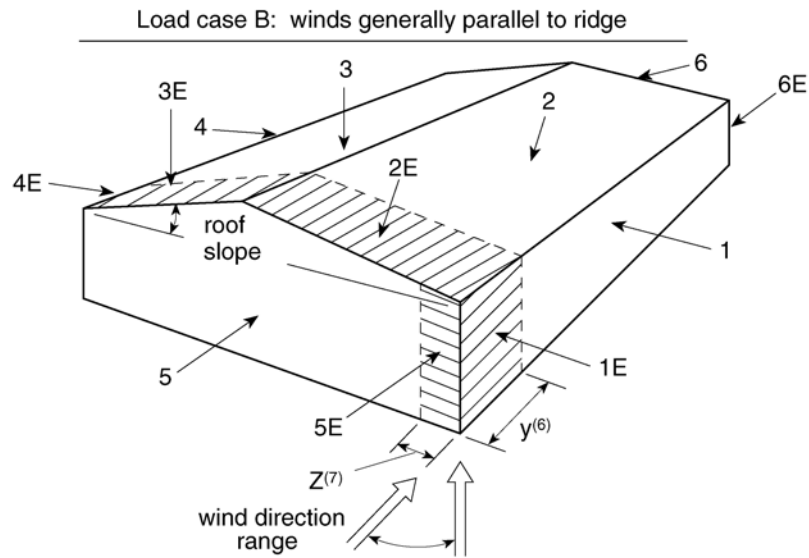
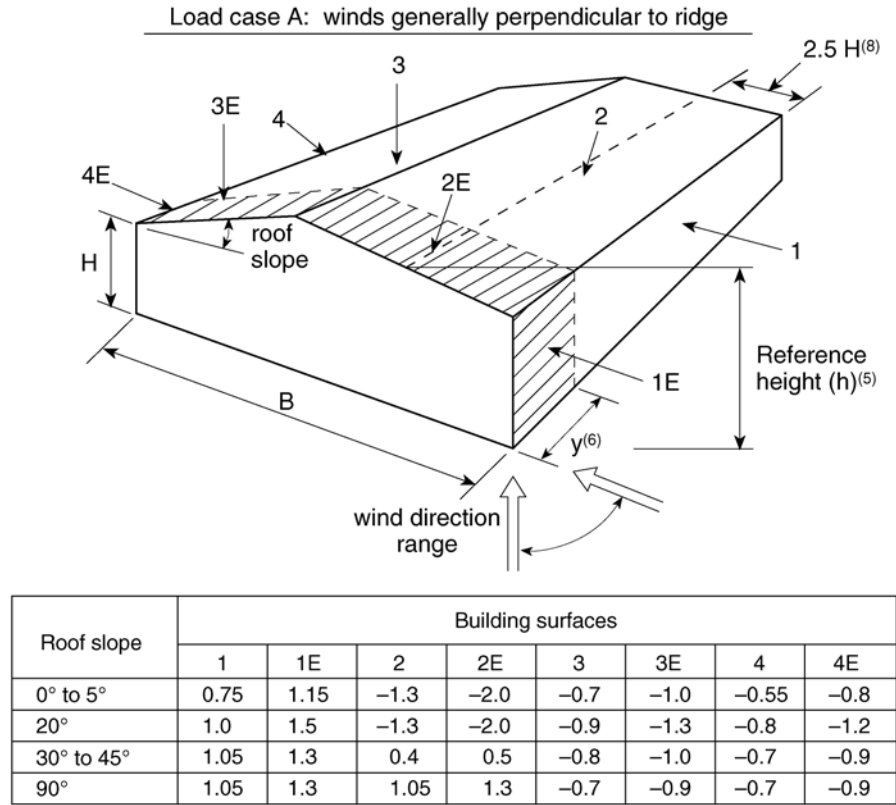

Roof slope	Building surfaces											
	1	1E	2	2E	3	3E	4	4E	5	5E	6	6E
0° to 90°	-0.85	-0.9	-1.3	-2.0	-0.7	-1.0	-0.85	-0.9	0.75	1.15	-0.55	-0.8

EG00920B

Figure I-7
External peak composite pressure-gust coefficients, $C_p C_g$, for primary structural actions arising from wind load acting simultaneously on all surfaces

Provision	Erratum	Date of Issue
-----------	---------	---------------

Commentary I (continued)

Figure I-11

This Figure was replaced with the following one:

07-12-01

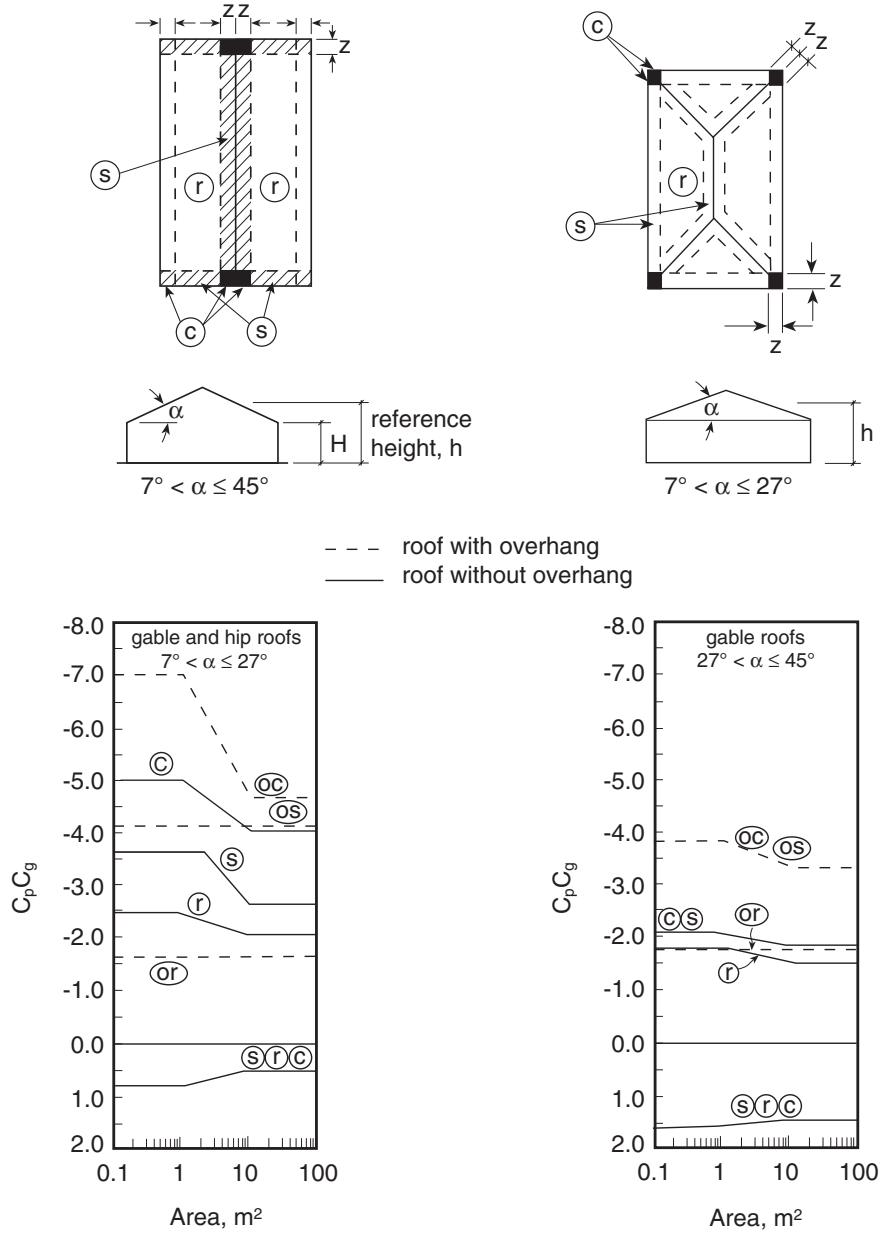

EG00924C

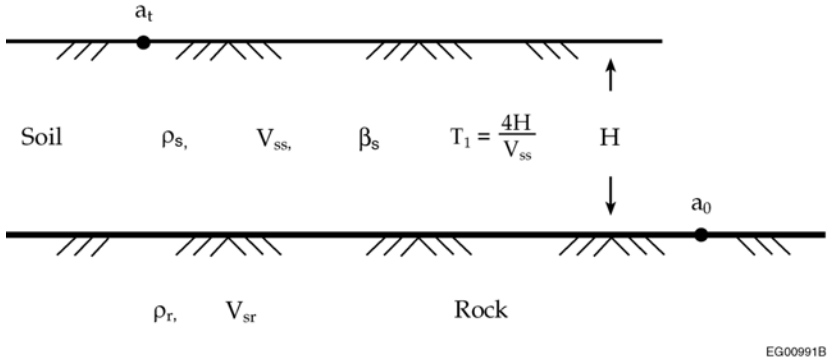
Provision	Erratum	Date of Issue
Commentary J		
Figure J-7	<p>This Figure was replaced with the following one:</p> 	07-12-01
Paragraph 205	<p>The following text was deleted from the last sentence:</p> <p>...the use of capacity design principles for ductile structures is specified in the CSA material standards for concrete (CSA A23.3^[49]), steel (CAN/CSA-S16^[61]), masonry (CSA S304.1^[78]), and wood (CAN/CSA-O86^[47]);...</p>	07-12-01
References	The standard designation in reference number [42] was corrected to read "CAN/CSA-S6-00"	07-12-01
Commentary K		
Paragraph 10	The reference to Figure K-3 was corrected to read Figure K-1	07-12-01
Commentary L		
Paragraph 27	The word "loads" in the title and in the first sentence was changed to "effects"	07-12-01

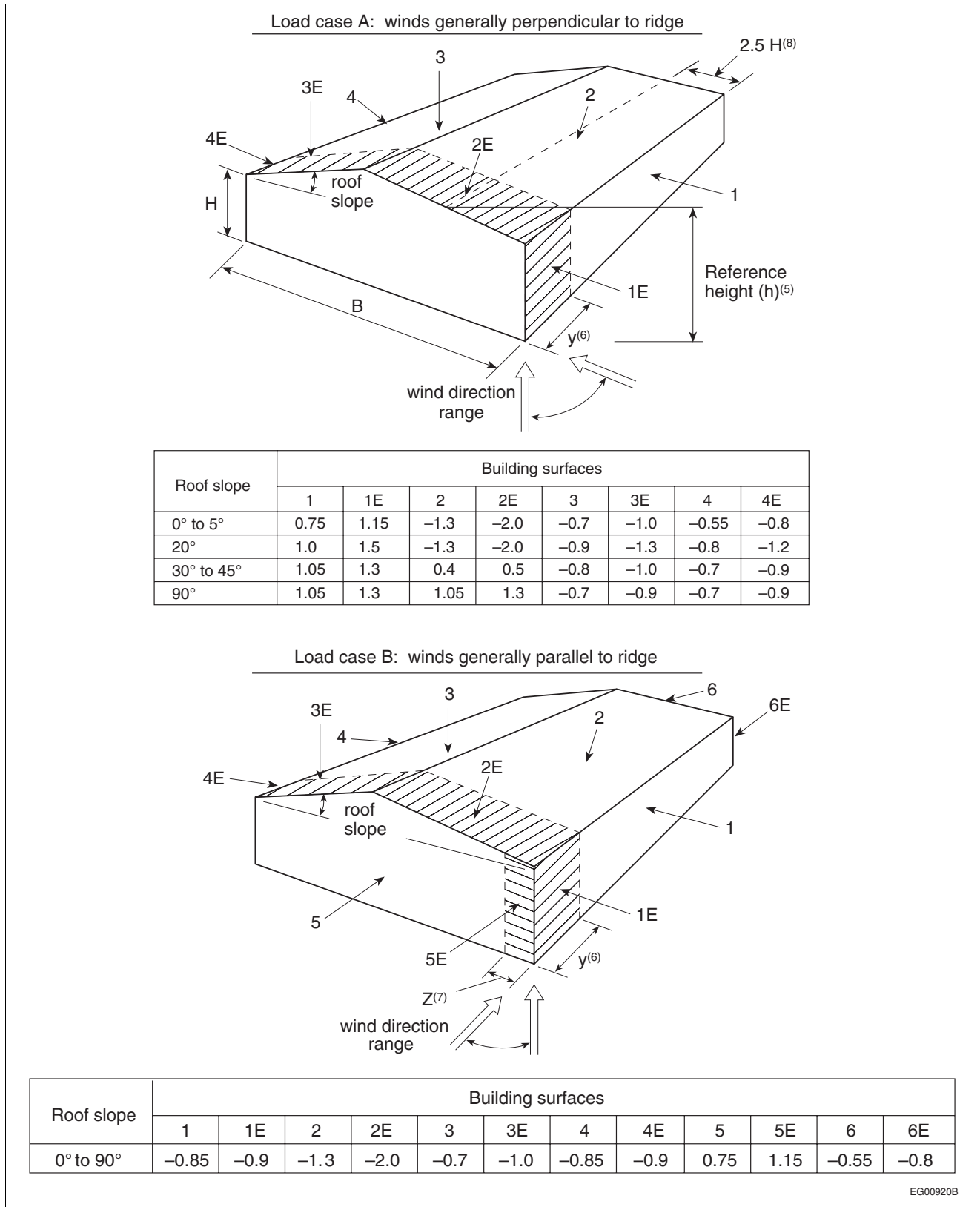

Figure I-7
External peak composite pressure-gust coefficients, $C_p C_g$, for primary structural actions arising from wind load acting simultaneously on all surfaces

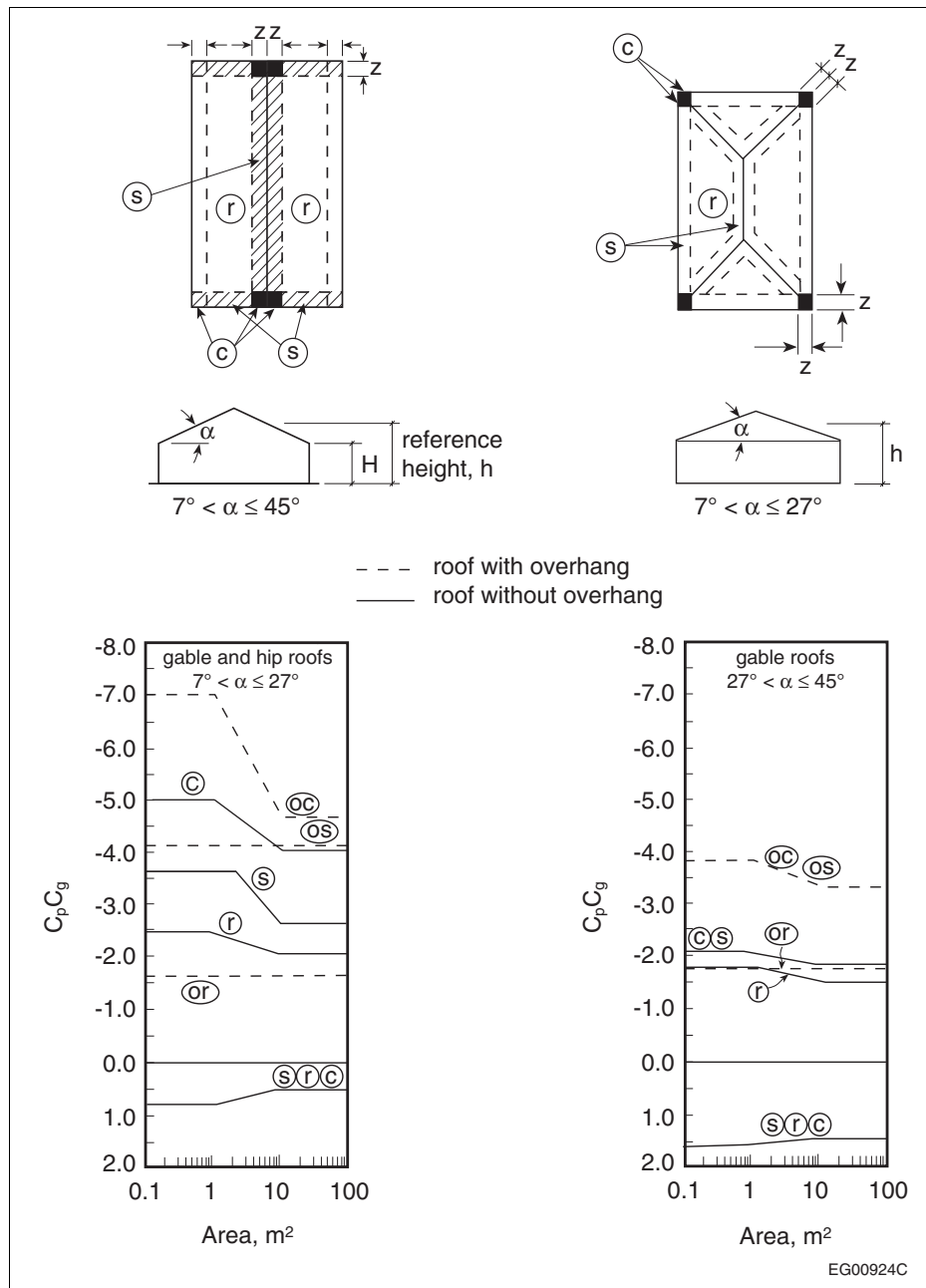

Figure I-11

External peak composite pressure-gust coefficients, $C_p C_g$, on single-span gabled and hipped roofs with a slope of 7° or greater for the design of structural components and cladding

Notes to Figure I-11:

- (1) Coefficients for overhung roofs have the prefix "o" and refer to the same roof areas as referred to by the corresponding symbol without a prefix. They include contributions from both upper and lower surfaces.^{[24][44]}
- (2) The abscissa area in the graph is the design tributary area within the specified zone.
- (3) End-zone width z is the lesser of 10% of the least horizontal dimension and 40% of height, H , but not less than 4% of the least horizontal dimension or 1 m.
- (4) Combinations of exterior and interior pressures must be evaluated to obtain the most severe loading.
- (5) Positive coefficients denote forces toward the surface, whereas negative coefficients denote forces away from the surface. Each structural element must be designed to withstand the forces of both signs.
- (6) For hipped roofs with $7^\circ < \alpha \leq 27^\circ$, edge/ridge strips and pressure-gust coefficients for ridges of gabled roofs apply along each hip.^[45]

Commentary J

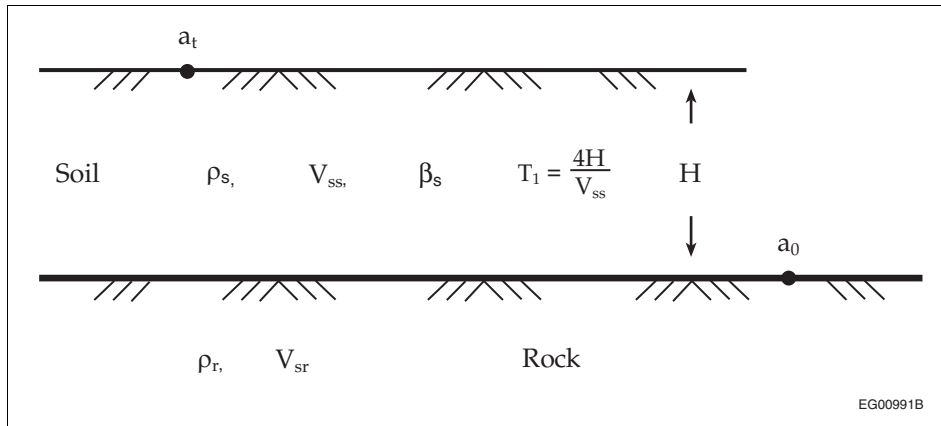

Figure J-7
Elastic layer on elastic half-space

Nonlinear Site Amplification

67. Under strong shaking, the response of the soil will be nonlinear. The shear modulus and damping are strain dependent and therefore the larger strains, associated with strong shaking, reduce the effective shear moduli and increase the damping. The shear strength of the soil also puts a limitation on the magnitude of the surface acceleration because the seismic waves cannot generate shear stresses greater than the mobilized shearing resistance of the soil. Field evidence shows that the nonlinear behaviour of soils causes the ground motion amplification factors to be dependent on the intensity of shaking.
68. In Figure J-8, Idriss^[31] has conveniently summarized the nonlinear relationship between peak accelerations on soft soil sites and those on associated bedrock sites. The median curve is based on data recorded in Mexico City during the 1985 Michoacan earthquake and on strong motion data from the 1989 Loma Prieta earthquake. The part of the median curve for peak rock accelerations greater than 0.2g is based on 1-D site response analyses using the SHAKE computer program (Schnabel et al.^[32]). The curve suggests that, on average, the bedrock accelerations are amplified in soft soils until the peak rock accelerations reach about 0.4g. The higher amplification ratios between rock and soil sites, in the range of 1.5 – 4, are associated with rock acceleration levels of less than 0.10g, when the response is closer to being elastic. The increased nonlinearity of soft soil response at the higher accelerations reduces the amplification ratios because of the increase in hysteretic damping and the reduction in effective shear moduli.